

RADIO SERVICE DEPARTMENT

Bldg. #21

West Orange

N. J.

Bulletin #1

JANUARY 17, 1929.

---

SPECIAL SERVICE BULLETIN FOR EDISON RADIO SERVICE ENGINEERS

---

SUBJECT: "Elimination or the reduction of hum level in JR and JC chassis."

It is suggested the operations outlined below be followed in the sequence as written.

1. Remove power pack unit from chassis.
2. Reverse the secondary leads on the plate (power) transformer. With the power pack in it's normal position you will find these leads at the lower, bottom end of terminal board. The terminal lug at extreme bottom has attached to it two leads, one green covered wire and a yellow wire with red tracer, remove both of these leads and place them on the terminal just above and next to lowest terminal. Of course, placing the lead from second terminal on lowest terminal.
3. Remove the five bolts securing the filter condenser to power pack frame, permitting access and removal of all A.C. leads.
4. The filament leads to the 281 rectifier tube must be removed from cable and twisted together, then replaced in former position, back of filter condenser position.
5. Twist the 110 volt A. C. feeders, which connect the plug and line switch panel to primaries of power transformers. To do this, of course all cable lacing must first be removed from wires. After the twisting operation it will be unnecessary to replace lacing.
6. Braid the three leads which run from line switch points to primary terminals of Plate transformer.
7. Replace the Power pack unit, bolting to chassis frame.
8. It is advisable, because of color code used in cable from audio unit to power pack unit, to replace all these cable leads. Then, removing the R.F. (red) 226 filament leads, that is, unsolder them at transformer terminal block, pull them back along cable route, twist them and replace in regular position, soldering them to same terminals on transformer terminal block.
9. In the same manner twist the 227 detector filament leads.
10. In the same manner twist the 226 audio filament leads.

Sheet #2.

Bulletin #1 Continued.

11. Remove the hum adjuster leads at the audio terminal strip. Twist these leads for each adjuster and resolder ends to terminal board.

12. Unsolder the pilot light leads at the pilot light. Pull the leads through condenser platform. Twist these leads and pull through platform hole and resolder to pilot light terminals.

Hooking up chassis and adjusting hum adjusters for minimum hum should reveal marked improvement in the elimination of "hum".

Particular care must be exercised in the selection of a 227 tube, for should this tube be defective a pronounced hum will result. This generally is a microphonic effect and can only be reduced effectively by attaching the baffle board (celotex) direct to speaker frame and withdrawing speaker about two inches from front of cabinet. No sacrifice of tone quality will result from this operation.

Operations numbered three, four, five and six are not absolutely necessary. If all the remaining operations are performed remarkable results will follow.

Neither do we especially recommend manipulating speaker and baffle positions. These measures are only cited for use in "extreme" cases where a particular customer is to be pleased at any cost.

THOS. A. EDISON, INC.;  
Tech. Ass't. to Vice Pres.  
RADIO-PHONO. DIVISION.

ELIMINATION OF HUM  
TO ACCOMPANY  
SERVICE BULLETIN #1

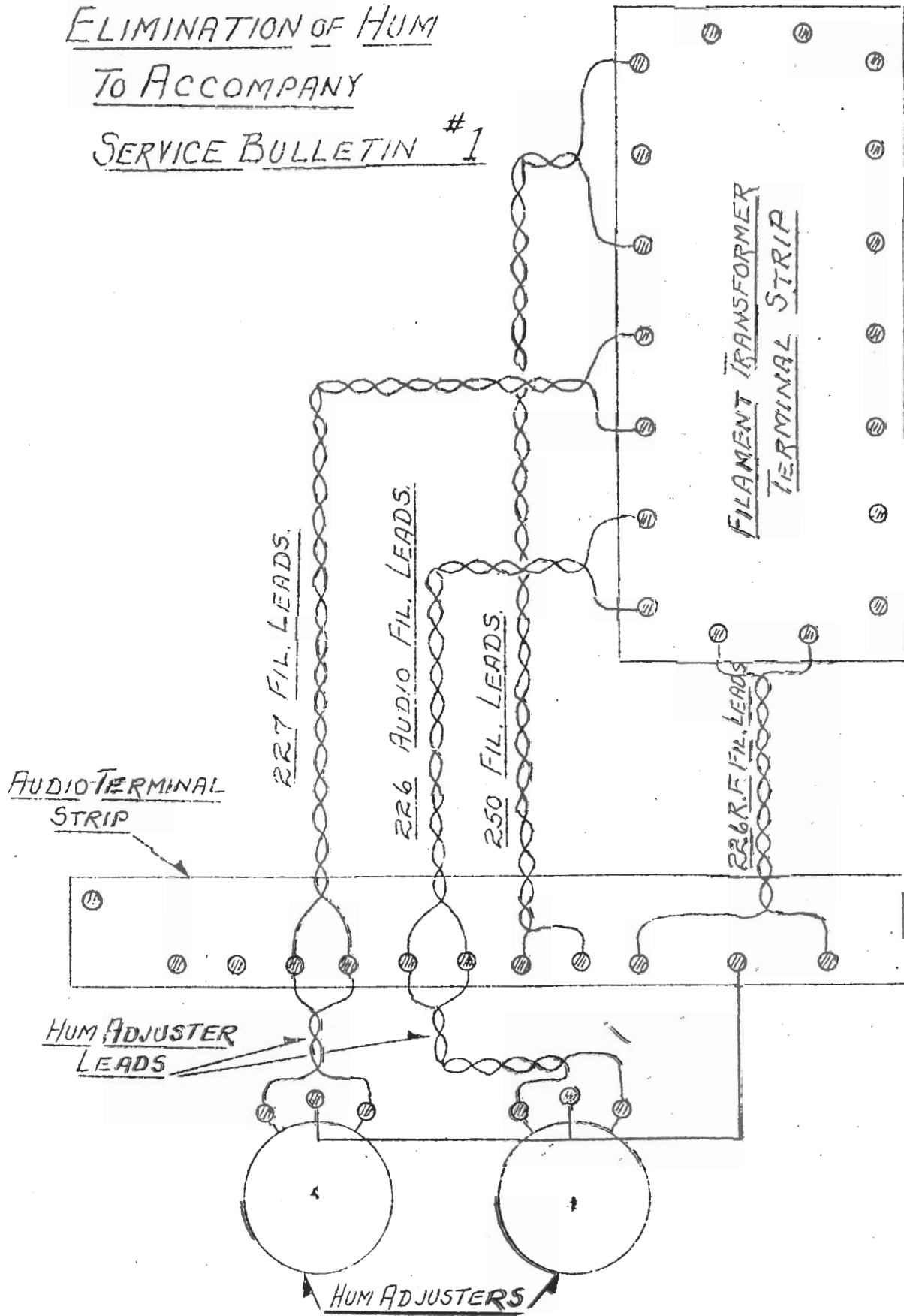

RADIO SERVICE DEPARTMENT

Bldg. 31

West Orange, N. J.

Bulletin #3

JANUARY 31, 1939

SPECIAL SERVICE BULLETIN FOR EDISON RADIO SERVICE ENGINEERS

SUBJECT: "Ventilation of Power Packs in C-1 Models to prevent over-heating of filter condensers and loss of wax."

1. Remove the wood bracket strips securing the power pack at both ends and top. Three wood screws hold each strip.
2. Remove the pack from cabinet.
3. Place two one inch strips in bottom of cabinet, one at each end of the power pack, thus raising the pack one inch from the bottom of cabinet, providing ample ventilation through pack.
4. Replace the bracket strips at each end and top of pack, securing the pack in position.
5. Where set is installed in customer's home and if no strips are available, place the bracket strips, (which have been removed from top) under the power pack, pulling the pack toward the rear of cabinet to prevent possibility of pack contacting with cone of lower speaker.
6. It is imperative that this be done with every C-1 installation, to prevent possibility of damage to filter condensers and wiring in power pack. Hence, please bear this in mind when making service calls on all C-1 models--elevate the power pack to provide sufficient ventilation, whether or not trouble exists in the power pack.
7. Of course the above measures are unnecessary if vent holes have been provided or already exist in bottom floor of the cabinet.

THOS. A. EDISON, INC.,  
T. A. to V. P.  
RADIO-PHONO DIVISION

RADIO SERVICE DEPARTMENT

Bld'g. 21

West Orange, N. J.

BULLETIN #4 (Revised)

JANUARY 22, 1929.

---

SPECIAL SERVICE BULLETIN FOR EDISON RADIO SERVICE ENGINEER

---

SUBJECT: "Outline of procedure for the handling of Parts Orders".

1. Use order book, preferably the one supplied by this office.
2. Give chassis number. Refer to your parts list, giving proper name of part and the correct part number, thus avoiding errors in shipment of parts.
3. Do not send dealers' orders to the factory. Send them to the branch office or distributor's office from which you are detailed.
4. Do not send your own replacement orders to the factory. Your branch or distributor will supply the parts you need and all defective parts must be returned to your jobber, who in turn sends these defective parts to the factory.
5. Due to lack of organization in the proper handling of repair and replacement parts much confusion has been experienced in the past few months.

Parts orders have been directed to the factory. Some of these orders have been noted on service report forms, not a few of these orders have been picked from personal letters to the department manager. All of which adds to the general confusion and delay in handling parts orders.

A complete stock of repair and replacement parts is being prepared and shipped to each Edison Branch and to each Independent Distributor of Edison Radio Products.

Order books are being mailed to service engineers.

Adhere strictly to the above rulings and avoid confusion and delay in handling parts orders in the future.

P. J. McGee, T. A. V. P.  
Radio-Phono. Division  
THOMAS A. EDISON, INC.

RADIO SERVICE DEPARTMENT

Bld'g. 21

West Orange, N. J.

BULLETIN #5,

JANUARY 22, 1929

---

SPECIAL SERVICE BULLETIN FOR EDISON RADIO SERVICE ENGINEERS

---

SUBJECT: "Phonograph and pick-up Troubles which may be experienced with Edison Combination Models."

1. Seven sheets of detailed information follow, outlining the cause and remedy for such troubles,

2. Supplements to this bulletin will be issued from time to time, as new troubles are found to exist and the remedies will be treated in detail.

P. J. McGee, T. A. V. P.  
RADIO-PHONO DIVISION  
THOS. A. EDISON, INC.

TO ACCOMPANY BULLETIN # 5

HOW TO INSERT NEEDLE IN PICK-UP HEAD

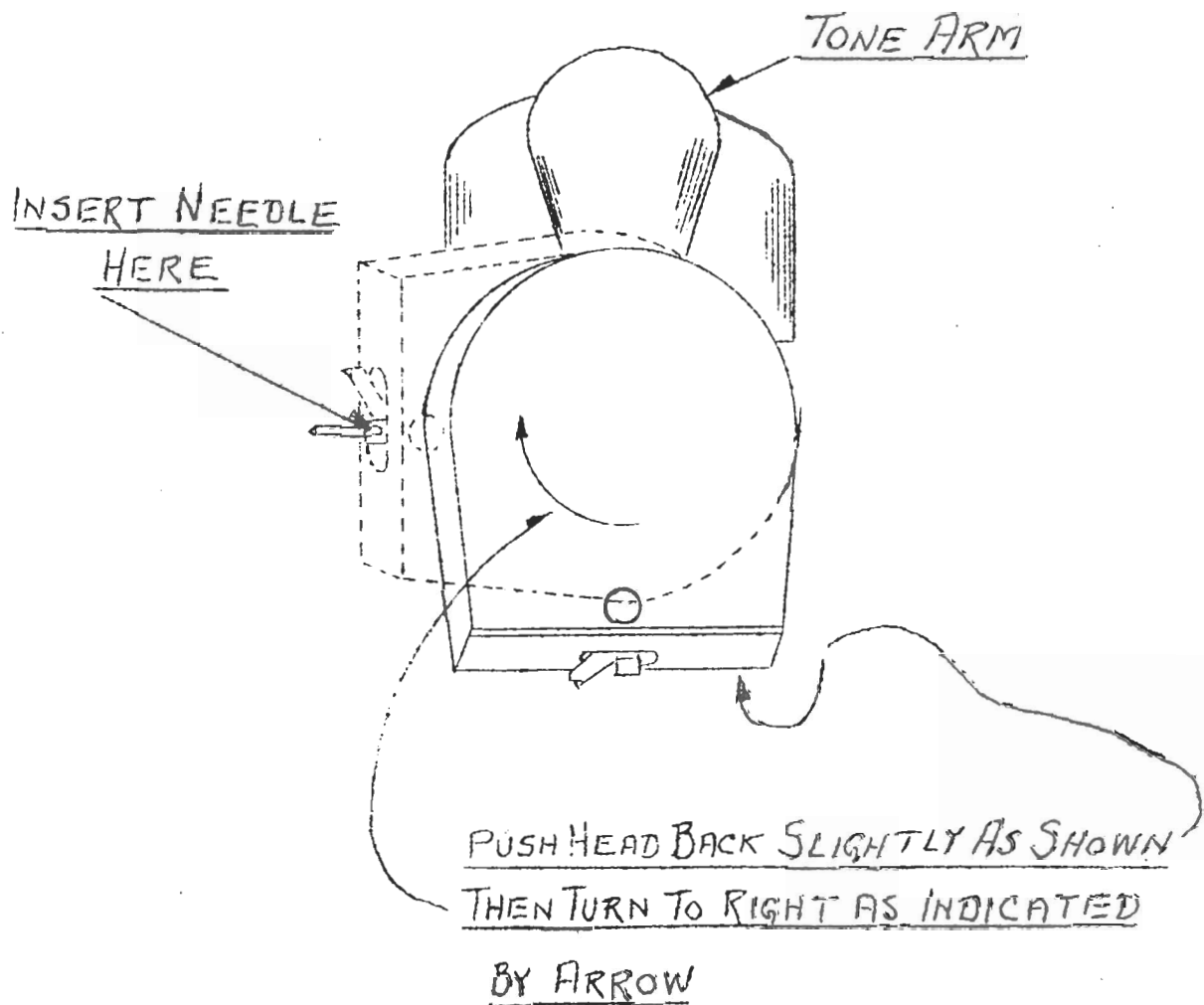

POSSIBLE TROUBLES IN PHONOGRAPH SIDE OF RADIO-PHONOGRAPH  
COMBINATION MODELS.

QUALITY OF MUSIC BELOW STANDARD

1 - Music Buzzy or Blasty

- (a) NEEDLES LOOSE IN ARMATURE. This will make the music weak and of very poor quality and will introduce an excessive amount of scratch. This trouble sometimes appears if a needle has been broken off in the armature or if the armature hole has become partially plugged with some other substance, which prevents the new needle from being introduced to its correct position.
- (b) DIAMOND POINT CHIPPED OR MISSING. In this case any hill and dale records played will become badly scratched. The pickup should be returned to the factory for a new diamond point.
- (c) PICKUP VERY LOOSE ON PICKUP ARM. This will sometimes cause a kind of rattling sound which is especially noticeable on low notes.
- (d) ARMATURE FLAG NOT CENTRAL. If the damping at the top of the armature flag is not correctly adjusted, the quality may become very bad, especially if the flag touches one of the pole pieces. Adjustment should be made and then tested AFTER THE MAGNET HAS BEEN REPLACED. Due to the friction between the rubber damping piece and the sides of the slot in which it is placed, there is a tendency for the rubber to "creep" a little after adjustments have been made. For this reason, it is usually best to over-adjust slightly and then come back a little. It is also well to work the rubber lightly in order to make it assume its final position as soon as possible. When correctly adjusted, placing the weight of the pickup on the diamond point should cause an observable but very slight movement of the armature. The flag should be set so that it is no farther from its central position when playing Edison records than it is when playing lateral cut records.
- (e) ARMATURE FLAG BENT. The flag should be straightened with as little hammering and working as possible.
- (f) POLE PIECES NOT IN LINE. If the pickup coil is so thick that it will not allow the pole pieces to seat, the faces of the pole pieces may be out of alignment. Such a pickup should not have left the factory and should be returned if found. As a temporary measure a thin shim can be placed under the pole piece to bring it into line.
- (g) CLAMPING PLATES LOOSE. If the lower clamping plates are found to be loose, squeeze them together as tightly as possible with the fingers and screw in place. If possible, press the armature in at the same time.
- (h) IRON CHIP IN GAP. A very small chip bridging the gap between the pole piece and the flag will cause extremely poor quality and a loss of volume in the pickup. Such chip can hardly ever be removed without first taking off the magnet.



- (i) **INSUFFICIENT CLEARANCE AROUND ARMATURE.** If the armature is not properly centralized it may touch some part of the mounting, coil, or cover. If it touches a metal part, a rattle is apt to result while if the coil touches the armature, there may be a loss in high frequency and a reduction in volume.
- (j) **DAMPING AT TOP OF ARMATURE TOO TIGHT OR TOO LOOSE.** If this damping is too tight, the armature may be so stiff that the stylus is unable to follow the grooves in the record. The result will probably be a loss in low frequency and a tendency to blast on loud notes. If the damping is too weak, the flag may actually leave one of the rubber pieces when it moves to the opposite side. This introduces a break into the even variation in forces on the flag and will introduce distortion. Furthermore, if the damping is very weak, there is a chance that the flag will eventually work over to one pole or the other and remain there.

## 2 - MUSIC VERY SHARP AND STRIDENT,

- (a) **WRONG NEEDLE.** The pickup is designed for use with a medium needle. Loud and extra loud needles will often sound very harsh.
- (b) **FILTER CIRCUIT OPEN.** The chief function of the filter is to reduce the stridency of lateral cut records. Most hill and dale records need very little filter. If the filter is working properly, there should be a marked increase in stridency and surface noise on lateral cut records when the filter is disconnected.

## 3 - MUSIC WEAK,

- (a) **GAP TOO WIDE AT TOP OF ARMATURE.** The distance between the faces of the pole pieces should be approximately .070". As the screws holding the pole pieces to the mounting have slight clearances in the holes, it is possible to move the pole pieces back and forth a few thousandths of an inch. If the gap remains too large when the pole pieces are pushed in as far as they will go, the pickup should be returned to the factory.
- (b) **DAMPING AT TOP OF ARMATURE TOO TIGHT.** See above.
- (c) **ARMATURE FLAG BENT.** See above.
- (d) **ARMATURE OF POOR QUALITY.** If the armature should ever be badly bent and then straightened by hammering or other violent working, its quality will be very poor, due to the fact that much of the value of the heat treatment has been lost. The service man cannot correct this.
- (e) **LOW VOLTAGE ON 250 TUBE.** If the voltage on this tube is not up to normal, the volume will be greatly reduced. It would be well to check over the rectifier and first audio tube also.
- (f) **VOLUME CONTROL OF TOO LOW A RESISTANCE.** For maximum volume, the volume control which shunts the pickup should be able to open to about 20,000 ohms. There is, however, considerable latitude in this figure as two or three thousand ohms one way or the other will make very little difference.

- (g) MAGNET WEAK. If magnets have been removed from two pickups and placed together they may sometimes demagnetize each other somewhat. The magnets used, however, are extremely strong and permanent, and there should be little trouble from this source.
- (h) FIRST AUDIO TRANSFORMER IMPROPERLY CONNECTED. If the pickup is connected across the entire primary of the first audio transformer instead of being connected to the center tap, there will be a loss of volume.

#### 4 - Lack of Bass.

- (a) DAMPING AT TOP OF ARMATURE TOO TIGHT. See above.
- (b) SPEAKERS NOT IN PHASE (SENIOR). If the speakers are out of phase, the high frequencies are very little effected while the very low frequencies are almost completely cut out.

#### 5 - Lack of "Highs."

- (a) NEEDLE TOO SOFT.
- (b) FILTER TOO HEAVY. The filter consists of a capacity, an inductance and a resistance in series. The major part of the resistance consists in a number of turns of high resistance wire wound on the outside of the inductances. If these turns are omitted the filter will be too heavy. The filter used is a compromise inasmuch as far more filtering is required for lateral cut records than for the hill and dale type. Because of this some of the hill and dale records will always sound slightly overfiltered. The filtering action may be reduced by adding an external resistance in the filter circuit. This will make many of the lateral records very strident.

#### 6 - Certain Notes Exaggerated.

- (a) RESONANCE. In some of our tests it was found that certain organ notes produced a kind of blubbering sound in the pickup, especially on hill and dale records. Some of this cannot be eliminated but a great part of it was traced to "microphoning" between the pickup and loud speaker. Most of this microphoning was eliminated by mounting the loud speakers on felt and by being careful not to press them tightly against the baffle board. When correctly placed, the loud speaker felt should just touch the baffle board and should not be compressed against it.
- (b) OVERLOADING OF TUBES, ETC. In the present chassis, the voltage on the 250 tube has been kept low because the rating of the 281 tube will not allow sufficient current to be drawn to enable the power tube to be worked at a higher level. For this reason the 250 tube may be overloaded on certain loud phonograph notes, or on notes which correspond to resonance peaks in the amplifying system. This is especially noticeable on hill and dale records. Heretofore, hill and dale records have not been used in connection with an electric pickup and have been pushed to the limit in an effort to make the mechanical reproduction compete with the result obtained from lateral cut electric

phonographs. Now that the hill and dale records are being used in an electric phonograph with greatly increased response to the low notes and a higher volume level of reproduction, a number of defects heretofore unnoticed have become apparent. In some cases, the defects are in the records themselves and cannot be overcome by adjustment of the pickup or playing mechanism. In other cases, an initially rather poor wave form from the pickup is exaggerated by the overloading of the 250 tube. This overloading may be reduced by turning down the volume control a little, and it will then usually be found that most of the blasting disappears or at least is greatly reduced. The resonant point of the pickup is high, while that of the loud speaker is low. The microphoning mentioned may sometimes be due to resonance of the cabinet itself or the turn table mounting.

#### 7 - Quavering Sound on Sustained Notes.

- (a) **ECCENTRIC RECORDS.** These are evident to the eye and cause a rise and fall in pitch with each revolution.
- (b) **WARPED OR WEDGE SHAPED RECORDS.** Sometimes the surface of records will be found to be more or less uneven or wavy. In this case the pickup will be seen to rise and fall slightly in coincidence with changes in the musical fluctuations produced.
- (c) **MECHANICAL DEFECTS IN MOTOR.** Sometimes a high frequency quaver is due to a "drunken" governor. This is due to faulty adjustment of the springs in the governor and is difficult to correct in the field. High spots on shaft and lack of lubrication may also cause quavering.

#### 8 - Bumping or Thudding Sound.

- (a) **TURN TABLE TOO LOW OR STOPS TOO HIGH.** Sometimes there is insufficient clearance between the corrugations on the bottom of the turn table and the leather washer which acts as a brake on the automatic stop. A thud or knock will be heard, depending on whether the turn table comes in contact with the leather washer or with the screw which holds the washer. In order to overcome this trouble, try bending the stop lever slightly to increase the clearance. The main mounting of some motors has been found to be out of line, thus causing the turn table to be tilted and to be too low at certain points. This trouble cannot usually be corrected by the service man and a new motor should be installed. Sometimes the trouble may be corrected by changing turn tables. After all adjustments are apparently correct, there may still be a knocking sound in some of the hill and dale records. This is apparently due to the records themselves, but the trouble has not yet been definitely located.

#### 9 - Cross Talk from Radio.

- (a) If cross talk is noticed when the phonograph is being played, the trouble is probably in the phonograph radio switch. When properly operating, this switch, besides connecting in the pickup, should ground the antenna and should eliminate cross talk from even the loudest stations. If the antenna is poorly grounded, a little cross talk may come thru.

10 - Certain Notes Appear Flat.

- (a) WEIGHT. The phonograph will occasionally slow down on certain loud notes if the weight on the diamond point or needle is too heavy. This is especially noticeable on lateral cut records when starting a loud selection like "The Stars and Stripes Forever," with a new needle. This may usually be corrected by reducing the weight on the stylus. An adjusting screw for this purpose will be found near the pickup arm pivot. The correct weight on the stylus point is 5 ounces.
- (b) CHIPPED DIAMOND. A broken point will tend to slow down the record and will be evident because of cutting or greatly increased wear.

11 - Music Generally High Pitched, Unpleasant and Unnatural.

- (a) INCORRECT SPEED. When all other adjustments are perfect, the quality of many records may be ruined by running them at too high or too low a speed. High speeds tend to make the records sound thin and lacking in bass, while low speeds introduce a barrel tone. The pointer on the speed regulator should be set to indicate normal speed at about 78 r.p.m. Heretofore, the normal speed for hill and dale records has been 80 r.p.m., but this will soon be changed to conform with the standard speed for lateral cut records of 78 r.p.m. If the majority of records to be played are of the hill and dale type, it may be well to assume some compromised speed of, say, 79.

MECHANICAL DEFECTS

1 - Record Skips or Repeats,

- (a) BIND IN PIVOT OF PICKUP ARM. In testing for this defect, be sure that the arm is swung in the playing position, for in the extreme position, even correctly adjusted arms will bind. Oiling the pivot points, or readjusting them may correct this defect.
- (b) WIRES CAUGHT IN PICKUP ARM MOUNTING. There is a possibility that the wires may jam in the mounting. The wires should be free and have plenty of slack and should leave the pickup arm as indicated in the diagram on the blueprint.
- (c) WIRES TWISTED. A twisted cable is much less flexible than two separate wires. For this reason, the pickup leads should not be twisted. If twisted, enough torque may be developed in moving the pickup arm to prevent proper tracking on hill and dale records where the grooves are very shallow.
- (d) PICKUP LOOSE OR CROOKED ON ARM. This may be due to a poorly made or worn slot in the pickup arm, or to a poorly located or undersized locating pin in the pickup. The service man can do little about this in the field.

- (e) MICROPHONING. In the course of our test, one machine was found which exhibited this defect so markedly (See No. 6 in the previous section) that it caused the pickup to skip on certain loud organ notes. In a few cases, a tendency to skip on extremely loud organ notes remains even when everything is in perfect adjustment. For the present, this will have to be considered a record defect and an effort will be made to eliminate possibility of skips from this cause in our future record production. The worst example so far found occurs in the final notes in organ selection "Chiquita." Another bad spot was found a little past the middle of the organ selection "Laugh Clown Laugh." Here the pickup will be found to "blubber" a little and will sometimes repeat. These are the only two bad selections found in the limited number of hill and dale records in our catalogue which have been tested. This trouble will probably occur only in organ records where there are very deep bass notes.
- (f) MACHINE NOT LEVEL.
- (g) OUT RECORDS. If records have been injured by playing needle type records with a diamond point and vice versa, skipping or repeating will probably result. These injuries are usually easily seen by an eye inspection.

2 - Pickup Cuts Records Or Produces Excessive Wear,

- (a) CHIPPED OR MISSING DIAMOND. Service man can do nothing about this but return pickup to factory.
- (b) TOO HIGH A PRESSURE ON THE RECORD. This may be corrected, as explained under paragraph 10a of the first section.

3 - Pickup Tends To Run Into Label Or Stick In Last Music Groove At End Of Groove.

- (a) MACHINE NOT LEVEL.
- (b) BIND IN PICKUP ON PIVOT OR TORQUE DUE TO PICKUP LEAD. See paragraph 1 of this section.
- (c) INCORRECT "TRACKING RADIUS." The relative location of the turntable spindle and pickup arm pivot point are determined by gauges at the factory. However, if the distance between these two points is too short, the pickup will tend to run into the label of the record. This may be corrected by "shortening" the pickup arm, or by moving the pivot point further away from the turntable spindle, but such adjustments would be difficult for the service man to make in the field. He can make a temporary adjustment by changing the level of the machine.

4 - Correct Motor Speed Cannot Be obtained.

- (a) SPEED CONTROL LEVER RUBS ON INSIDE OF CABINET. This will sometimes prevent a proper adjustment of the speed with the speed control knob. If this is found to be the case, the lever between the governor and the speed control cam may be bent to allow more clearance between it and the motor board support.

- (b) IMPERFECT ADJUSTMENT AT FACTORY OF SPEED CONTROL ROD. If the speed regulation is poorly adjusted at the factory, or if it has become damaged in shipment, the trouble may be corrected by bending the rod which runs from the governor to the speed control cam that is under the motor board.

5 - Brake Fails To Stop Turn Table Quickly.

- (a) LEATHER BRAKE PAD POORLY ADJUSTED. This trouble is usually corrected by rotating the leather brake pad on its retaining screw. In making this adjustment, care should be taken to note that the leather is not turned to such a position that it prevents the motor switch from opening when the brake is applied.

6 - Motor Continues To Vibrate When Phonograph Is Switched Off.

- (a) MOTOR SWITCH. Switching off the phonograph motor by means of the control and the motor board should put a brake on the turn table and at the same time open the electric circuit to the motor. Sometimes the motor switch is in poor adjustment and fails to open when the brake is applied. In this case a vibration can be felt in the turntable. The trouble is easily corrected by adjusting the contact point on the motor switch. The adjustment should be made with the turntable in place.
- (b) MOTOR CONNECTIONS. Motors have been found connected in a variety of ways and usually fail to operate unless connected as indicated in the diagram and the blue prints. Care should be taken to note that at least one of the wires passes thru the motor switch before reaching the motor coils.

7 - Rattle In The Cabinet,

- (b) One of the chief sources of rattle has been found to be the stay arms. Another source is needles in the needle cup. An attempt to reduce this source of rattle has been made by lining the needle cup with felt.
- (a) DYNAMIC SPEAKERS. The speakers will rattle if their voice coils are not properly centered or if paper has become buckled for any reason. The service man can adjust the centering of the voice coil but cannot correct buckled cones in the field.
- (c) LOOSE NEEDLE HOLDING-SCREW IN PICKUP. This may cause a rattle noticeable at low volume when playing hill and dale records. These screws will be made of bronze and should have a very slight bend to keep them tight in the pickup.

RADIO SERVICE DEPARTMENT

Bldg. #31

West Orange, N. J.

BULLETIN #6

JANUARY 30, 1929.

---

SPECIAL BULLETIN FOR EDISON RADIO SERVICE ENGINEERS

---

SUBJECT: "Proposed factory changes in chassis design affecting  
JR and JC Models".

1. Change wire & Shield Assembly #6 #34551 as per sample. This change effective on Sets after serial #7900. Reason for change is simplify assembly.
2. Change #8 cable #34606 as per sample using twisted pair filament leads. This change effective on sets after serial #7900. Reason for change to reduce hum.
3. Change #6 Cable Assembly. #34519 as per sample using twisted pair filament leads. This change effective on sets after serial #7900. Reason for change to reduce hum.

P. J. McGee, T. A. V. P.  
RADIO-PHONO DIVISION,  
THOS. A. EDISON, INC.

RADIO SERVICE DEPARTMENT

Bldg. #21

West Orange, N. J.

BULLETIN #7

JANUARY 30, 1929

---

SPECIAL BULLETIN FOR EDISON RADIO SERVICE ENGINEERS

---

SUBJECT: "The use of an external and separately excited dynamic speaker in connection with Models R-2; R-1 and C-2."

1. Connect voice coils in series.
2. External or additional speaker must be separately excited, that is the field of the external speaker must be excited direct from power line and must not be hooked up in connection with speaker field in set.
3. Approximately five percent loss of volume may result with this duplex speaker arrangement.
4. Such an installation has been arranged satisfactorily by an Orange dealer and is employed in a local hotel where the use of an additional speaker is desired, in a room removed from the set itself, and at an approximate distance of seventy-five feet. In this particular instance a Fada Dynamic Speaker was employed with excellent results.
5. This case is merely cited for your information and guidance in the event you are faced with similar problems in the field.

P. J. MCGEE, T.A.V.P.  
RADIO-PHONO DIVISION,  
THOS. A. EDISON, INC.

Ediphoned-T.



SKETCH TO ACCOMPANY BULLETIN # 7

CONNECTIONS FOR EXTERNAL AND SEPARATELY EXCITED DYNAMIC SPEAKER

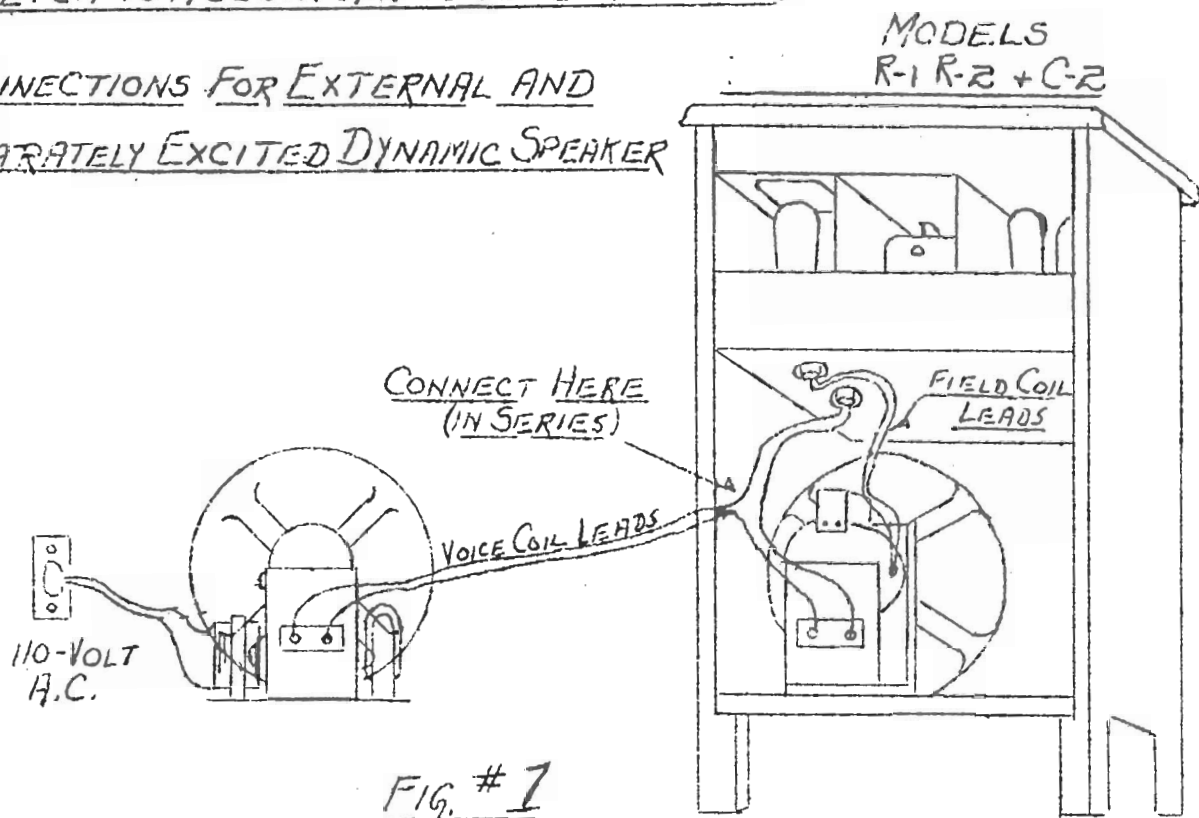

SKETCH TO ACCOMPANY BULLETIN # 8

SKETCH SHOWS CAUSE FOR LOSS OF VOLUME IN PICK-UP.

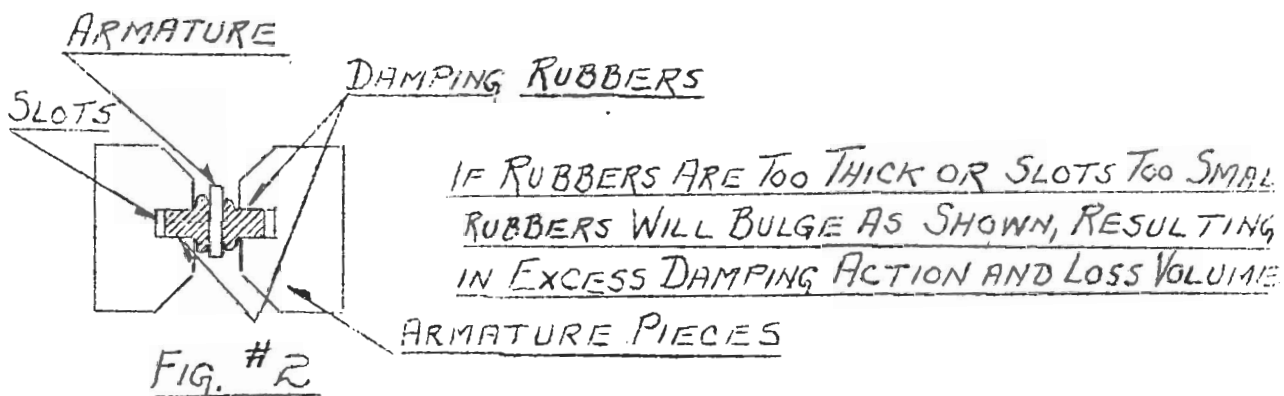

NOTE - TO CORRECT THIS CONDITION WIDEN SLOTS BY FILING SIDE WALLS, USING PLATINUM FILE OR EXTRA FINE FILE PERMITTING FREE MOVEMENT IN AND OUT OF DAMPING RUBBERS.

RADIO SERVICE DEPARTMENT

Bldg. #21

West Orange, N. J.

BULLETIN #8

JANUARY 30, 1929

---

SPECIAL BULLETIN FOR EDISON RADIO SERVICE ENGINEERS

---

SUBJECT: "Loss of volume in phonograph electric pick-ups".

1. Reports have been received from some points in the field complaining about the loss of volume in the electric pick-ups, used on Models C-2 and C-1.

2. A thorough investigation at the factory reveals the possibility of existence of the following troubles, which may be responsible for low volume or loss of volume.

(a) Excessive damping, the pole piece slots may be too small or too narrow, resulting in improper damping action or prevention of proper damping adjustment by means of the adjustment provided for this purpose. That is, damping may be increased to an excessive amount but decreased damping will not result from change in adjustments provided, the narrowed slots in pole pieces preventing damping rubber from returning or resuming its natural position in slotted recess. To correct this condition in an emergency it is recommended that pole pieces be removed and the slots widened by filing. However, great care must be exercised in this operation, using a platinum file, trying the damping rubber frequently to insure a "snug" fit.

(b) Excessive damping and subsequent loss of volume may also result from damping rubber which may be too thick. The result being the same as in (a). The remedy, likewise being the same as in (a).

3. Careful inspection for evidence of above conditions, will no doubt eliminate recurrence of such trouble in the future.

P. J. McGee, T. A. V. P.  
RADIO-PHONO DIVISION  
THOS. A. EDISON, INC.

RADIO SERVICE DEPARTMENT

Bldg. #21

West Orange, N. J.

BULLETIN #9

FEBRUARY 12, 1929.

---

SPECIAL BULLETIN FOR EDISON RADIO SERVICE ENGINEERS

---

SUBJECT: "Detector Shield".

1. The laboratory has provided a limited number of special detector shields, made from copper, with insulated mounting base, to be attached to front end of tube mounting panel.

2. With the shield in position, secured by the panel holding screws, the detector tube is visible from the rear of cabinet.

3. The presence of this copper shield grounded to chassis frame, through panel holding screws, eliminates the microphonic effect, body capacity and all of the hum which accompanies the use of a so-called poor detector tube.

4. Samples of this shield have been mailed to you and we desire a report on their adaptability to our chassis; if, in your opinion after trying out this shield in the field, you would recommend the use of a similar shield on our production chassis.

5. Your cooperation and immediate attention to this matter is necessary.

P. J. MCGEE, T.A.V.P.  
RADIO-PHONO DIVISION  
THOS. A. EDISON, INC.

TO ACCOMPANY BULLETIN #9  
LOCATION OF DETECTOR SHIELD

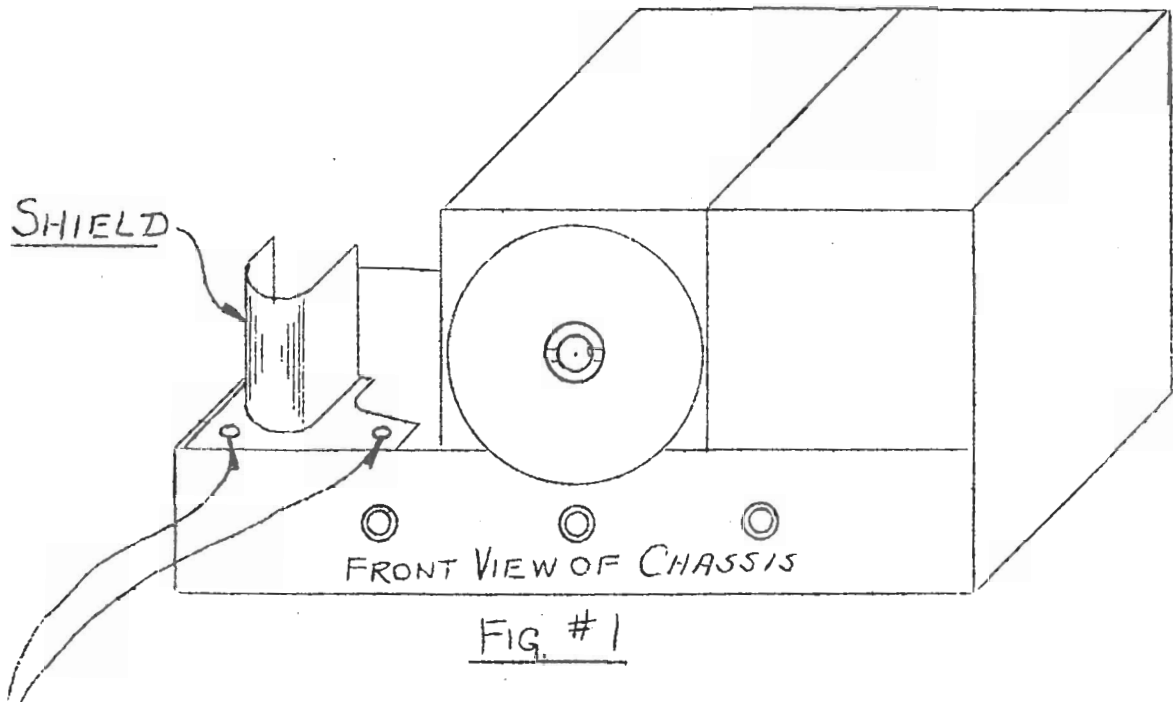

REMOVE TUBE SHELF SCREWS, PLACE SHIELD IN POSITION INDICATED AND REPLACE SCREWS THUS SECURING AND GROUNDING SHIELD TO CHASSIS FRAME.

NOTE, - MAKE SURE FIBRE INSULATING PLATE (SPACER) IS ATTACHED TO BASE OF SHIELD TO PREVENT SHORTING OF TUBE PRONG EYELETS.

RADIO SERVICE DEPARTMENT

Bldg. #21

West Orange, N. J.

BULLETIN #10.

FEBRUARY 15, 1929

---

SPECIAL BULLETIN FOR EDISON RADIO SERVICE ENGINEERS

---

SUBJECT: "Daily Service Reports".

1. Revised Daily Report Forms #4941 are being supplied. This record must be filled in completely. The various readings should be those which are taken when leaving the job.

2. Use one blank for each set which requires service adjustment or repair on chassis, or when persistent tube troubles have existed.

3. Do not fail to record model of set and serial number of chassis, the customer's complaint and what you did in nature of adjustment, repair or replacement.

4. Original copy of this report must be mailed to National Service Manager at Orange.

5. A few of our Radio Service Engineers have persistently ignored this ruling. We insist upon receiving these daily reports and details surrounding each service job.

6. A special trouble bureau is maintained in the General Manufacturing Division for the express purpose of dealing with reports and complaints of the service engineers in the field. This bureau is headed by Mr. Ralph H. Allen, Vice President of the Division. Therefore, it is important that your reports reach us regularly as well as promptly, furthermore that they be specific in detail.

7. Disregard for this ruling in the future will be sufficient cause for removal from service.

E. Trautwein,  
Ass't Radio Service Manager,  
THOS. A. EDISON, INCORPORATED.

RADIO SERVICE DEPARTMENT

Bldg. #21

West Orange, N. J.

BULLETIN #11

MARCH 13, 1929.

---

SPECIAL BULLETING FOR EDISON RADIO SERVICE ENGINEERS

---

SUBJECT: Lack of volume on Dynamic speakers.

One of our field Service Engineers has been consistantly reporting that he finds speaker bolts very loose. In order to get the best volume and reproduction the following bolts must be drawn up tight.

1. Voice coil holding bolts numbered 1,2,3 and 4 on attached diagram.

2. Voice coil contact bolts numbered 5 and 6 on same diagram.

William B. Chenowith,  
MGR. RADIO SERVICE DEPT.  
THOS. A. EDISON, INC.

# VIEW OF DYNAMIC SPEAKER

TO ACCOMPANY BULLETIN # 11.

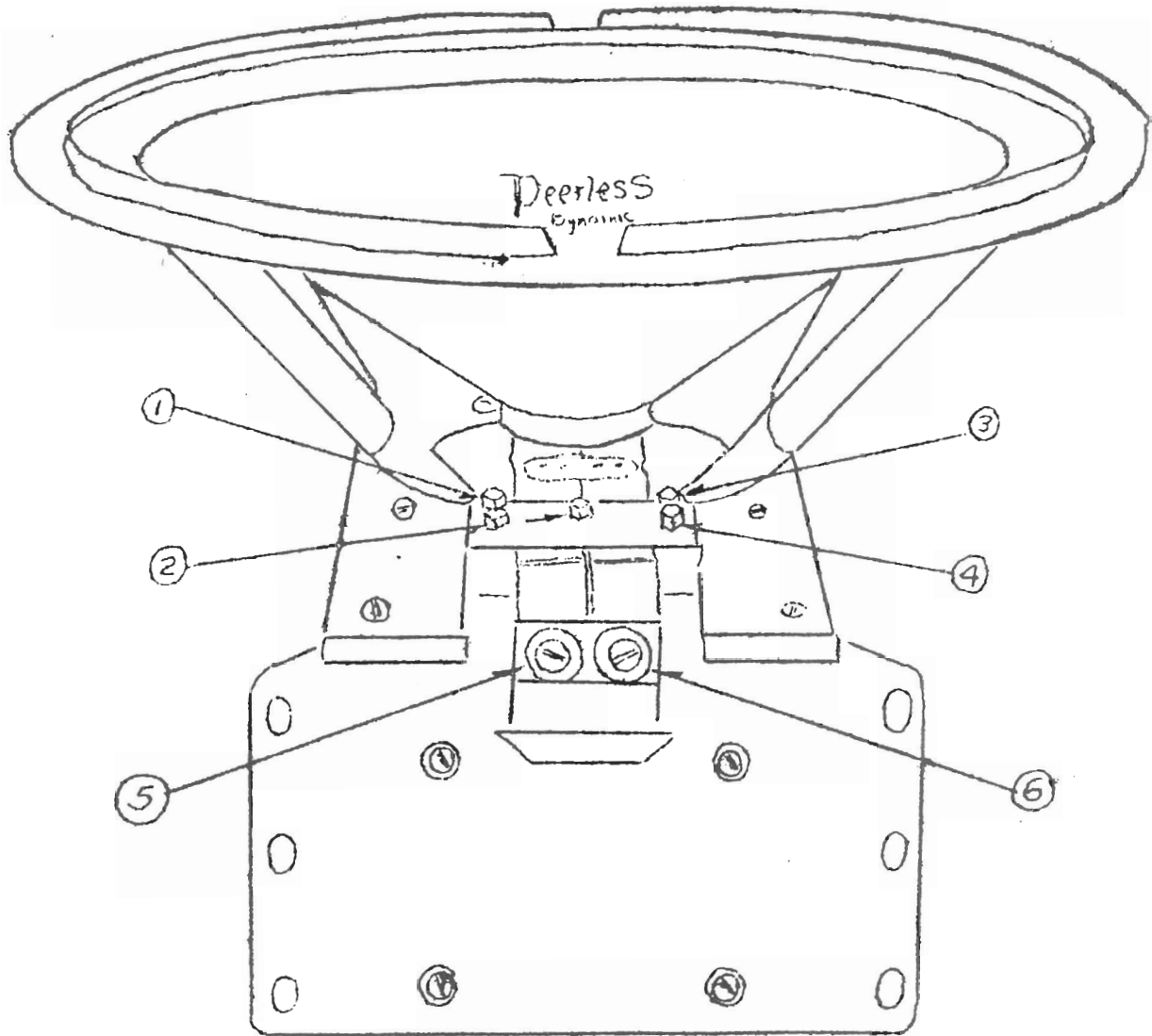

① VOICE COIL HOLDING BOLTS... ③

② " " " " ④

⑤ THESE CONTACT BOLTS MUST BE TIGHT

⑥ " " " " " "

RADIO SERVICE DEPARTMENT

Eldg. #21

West Orange, N.J.

BULLETIN #12

FEBRUARY 14, 1929

---

SPECIAL BULLETIN FOR EDISON RADIO SERVICE ENGINEERS

---

SUBJECT: "Regeneration Switches".

1. Mr. Bombe, Radio Service Engineer, operating from Richmond Branch Office, reports discovery of regeneration switches which are inoperative due to presence of resin within switch assembly.

2. Presence of resin results in imperfect contact or no contact at all -- result no oscillation.

3. The presence of the resin is probably due to the excessive use of resin on dial mechanism. The surplus resin dropping and collecting in the neck opening of regeneration switch, from where it filters to internal working parts of the switch, thereby insulating the contact points.

4. We suggest the removal of such resin from the switch by the application of alcohol, which dissolves the resin, rather than replacement of the switch with new one.

5. Also the installation of a special shelf which may be styled the "Resin drip pan", which will prevent recurrence of such troubles. Samples of this pan with instructions for installation are being mailed to all radio service engineers.

P.J. McGee, T.A.V.P.  
RADIO-PHONO DIVISION,  
THOS. A. EDISON, INC.

Ediphoned-R



RADIO SERVICE DEPARTMENT

Bldg. #21

West Orange, N.J.

BULLETIN #13

FEBRUARY 23, 1929.

---

SPECIAL BULLETIN FOR EDISON RADIO SERVICE ENGINEERS

---

SUBJECT: "Oscillation in Non-Oscillating Position of Regeneration Switch)".

1. On rare occasions a set may be found which will oscillate, with volume control turned on "full", with the regeneration switch in non-oscillating position.

2. Such a condition may result from the following irregularities:

- (a) Primary coils too near secondary coil center. The cement which holds the primary coil in position may have broken, permitting coil to float or change it's position within the secondary.
- (b) Open volume control or poor contact.
- (c) Shorted grid suppressors.
- (d) Reversed primary leads.

3. If no reason may be found for excessive oscillation, should it be encountered, the use of a 1200 ohm grid suppressor is suggested in the first radio frequency stage, replacing the 600 ohm which ordinarily will be found there.

4. When a 1200 ohm grid suppressor is not available, unsolder one end of the 600 ohm suppressor which is already in position. Connect a second 600 ohm grid suppressor in series, making a total of 1200 ohms. Invariably this additional grid resistance will permit operation in non-oscillating position without excessive oscillation, also resulting in less critical operation in the oscillating position.

5. See attached Figure for location of first radio frequency grid suppressor.

RADIO SERVICE DEPARTMENT  
RADIO-PHONO DIVISION  
THOS. A. EDISON, INC.

RADIO SERVICE DEPARTMENT

Bldg. #21

West Orange, N. J.

BULLETIN #14

FEBRUARY 19, 1929.

---

SPECIAL BULLETIN FOR EDISON RADIO SERVICE ENGINEERS

---

SUBJECT: "Burned out Antenna Coils".

1. A Western distributor reports a number of burned out antenna primary coils. Aside from Atmospheric discharges such as lightning we prescribe the following possible reasons which, under certain conditions, may contribute to the burning out of antenna coils.

2. The Attached figure indicates the location of possible short in chassis which will result in burned out primary IF THE GROUND WIRE IS ATTACHED TO ANTENNA POST OR IF ANTENNA ITSELF BECOMES GROUNDED.

3. To eliminate possibility of such ground-push connecting lugs as far away as possible from field coil plug shell, at X and from screw head, at Y. See figure 1.

4. If these grounds exist in chassis the chassis fuse will burn out repeatedly, as A.C. line plug is inserted in one position.

5. By reversing the position of A.C. line plug, the fuse will not burn out--with the ground still present in chassis. However, for safety's sake we recommend removal of the ground.

6. These grounds except in rare cases may be found only in some of the chassis bearing serial numbers below 3500.

7. If fuse trouble is experienced the "ground trouble" should be discovered and cured to avoid possibility of damage to antenna primary.

P. J. McGee, T. A. V. P.  
THOS. A. EDISON, INC.

TO ACCOMPANY BULLETIN #14.

"BURNED OUT ANTENNA COILS"

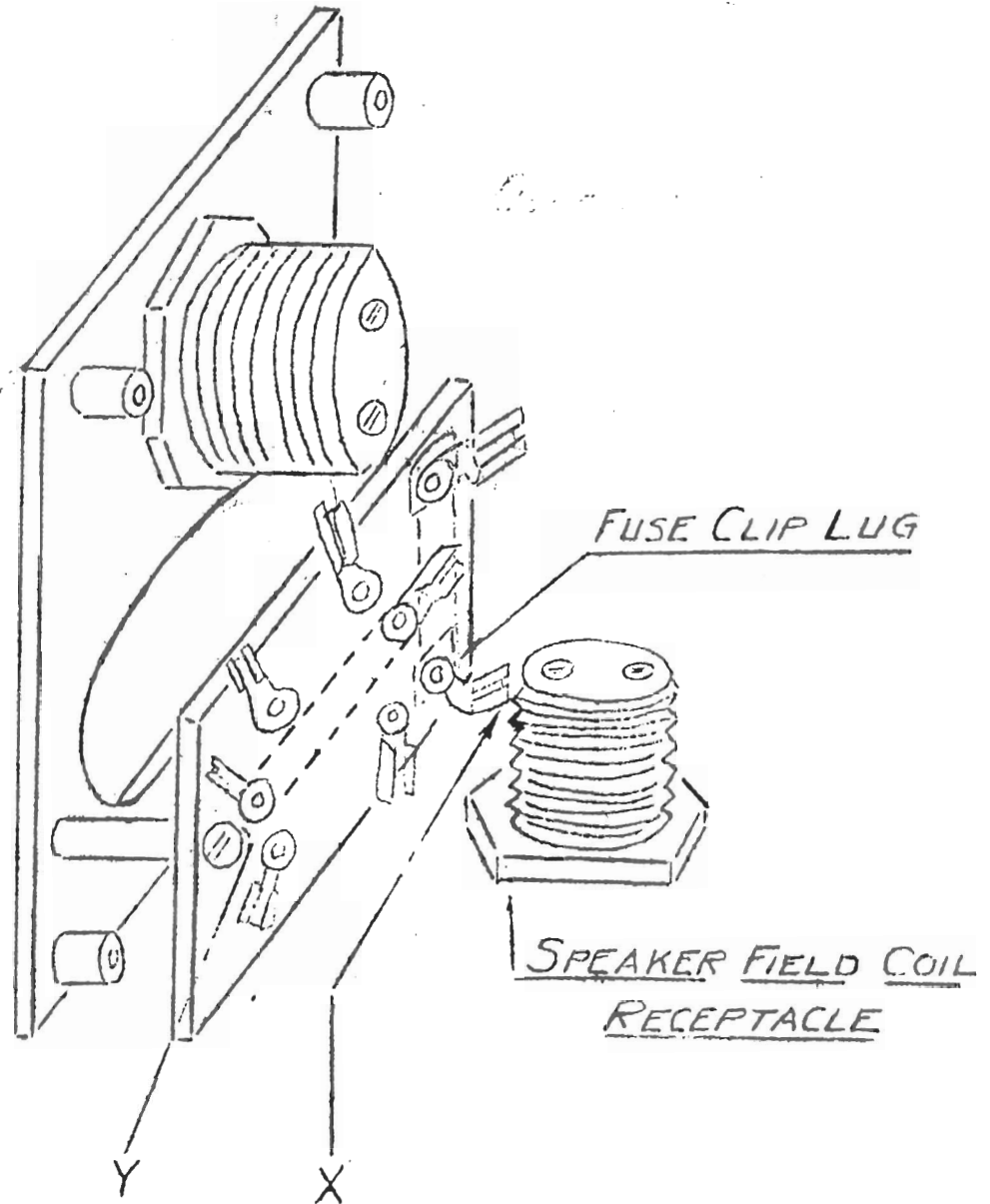

FIGURE 1.

RADIO SERVICE DEPARTMENT

Bldg. #21

West Orange, N. J.

BULLETIN #15

FEBRUARY 21, 1929.

---

Special Bulletin for Edison Radio Service Engineers

---

SUBJECT: "Proper procedure to be followed in Balancing Radio Frequency circuits, JR, JC and SC Chassis, as employed in Models R-1; R-2; C-2 and C-1.

1. For balancing, a very weak signal is desired. To secure this, use a short length of wire attached to antenna post.

2. Rotate dial to 100 position, condenser plates should now be fully enmeshed. Fix dial marker, as in figure 1, marker indicating exactly 100 on dial.

3. A station should be selected between 20 and 30 on the dial. If the station you select is broadcasting on a wave length of 260 meters, then set your dial exactly at 25. Leave dial in this position until tuning adjustments are complete. Any other station between these points may of course be selected.

4. Move regeneration Switch to Regenerative Position. With volume control turned up as much as possible but always just below the "spilling point", use balancing tool, turning the detector compensator adjustment screw, all the way in or out to locate the point of maximum volume. As the balancing tool is removed from adjustment screw a slight decrease in volume may be noticed. If so, set up or tighten the adjustment screw a trifle until maximum volume results with balancing tool removed. This condition will hold, probably with the remaining adjustment screws.

5. Do not change dial setting. Next and in a similar manner adjust the (adjoining) third R. F. compensating condenser - FOR MAXIMUM VOLUME.

6. Likewise adjust the second and first R.F. compensating condensers - FOR MAXIMUM VOLUME.

7. It is usually well to check the detector compensator setting as a final adjustment.

8. Now tune in a high wave station between 75 and 85 on the dial, and once more go through the procedure as outlined in preceding paragraphs 4,5,6, and 7. If you find only slight changes are necessary in compensator adjustments, set compensator adjusting screws half way between their settings for low wave and high wave. If, however, you find that it is impossible to get a point of maximum volume on one or more compensators when adjusting on a high or low wave signal, it is advisable to replace the gang condenser.

9. See attached figures for more details.

RADIO SERVICE DEPARTMENT  
RADIO-PHONO DIVISION  
THOS. A. EDISON, INC.

FRONT VIEW  
of  
CHASSIS

FIG. 1

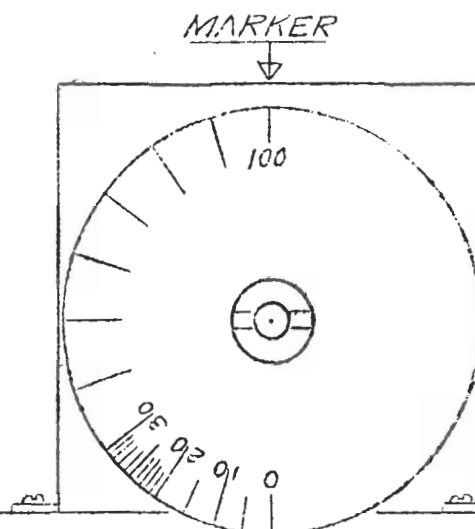

ROTATE CONDENSERS TO POSITION OF MAXIMUM CAPACITY. PLATES FULLY ENMESHED. SET MARKER DIRECTLY ABOVE 100.  
MAKE SURE POSITION OF MARKER REMAINS FIXED  
ROTATE DIAL TO A STATION - PREFERABLY BETWEEN 20 AND 30.  
PLACE SWITCH IN REG. POSITION - INCREASE VOLUME TO "NEAR REG." THEN ADJUST EACH COMPENSATOR FOR MAXIMUM VOLUME.

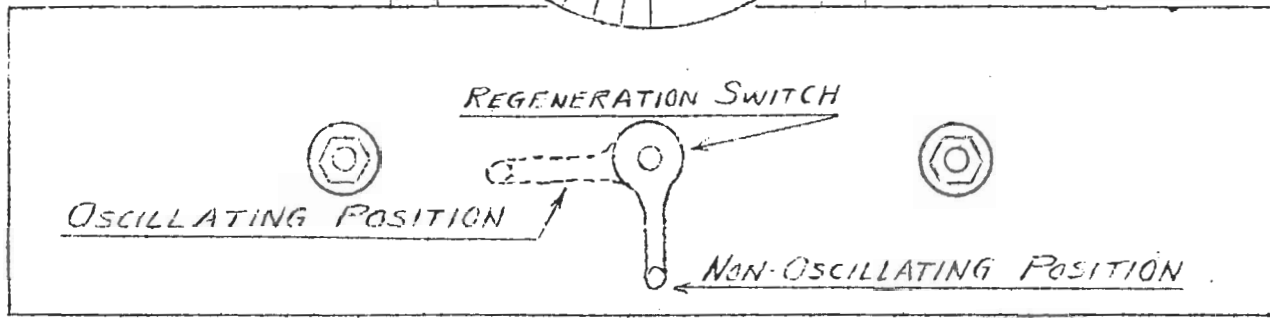

VARIABLE CONDENSER ASSEMBLY

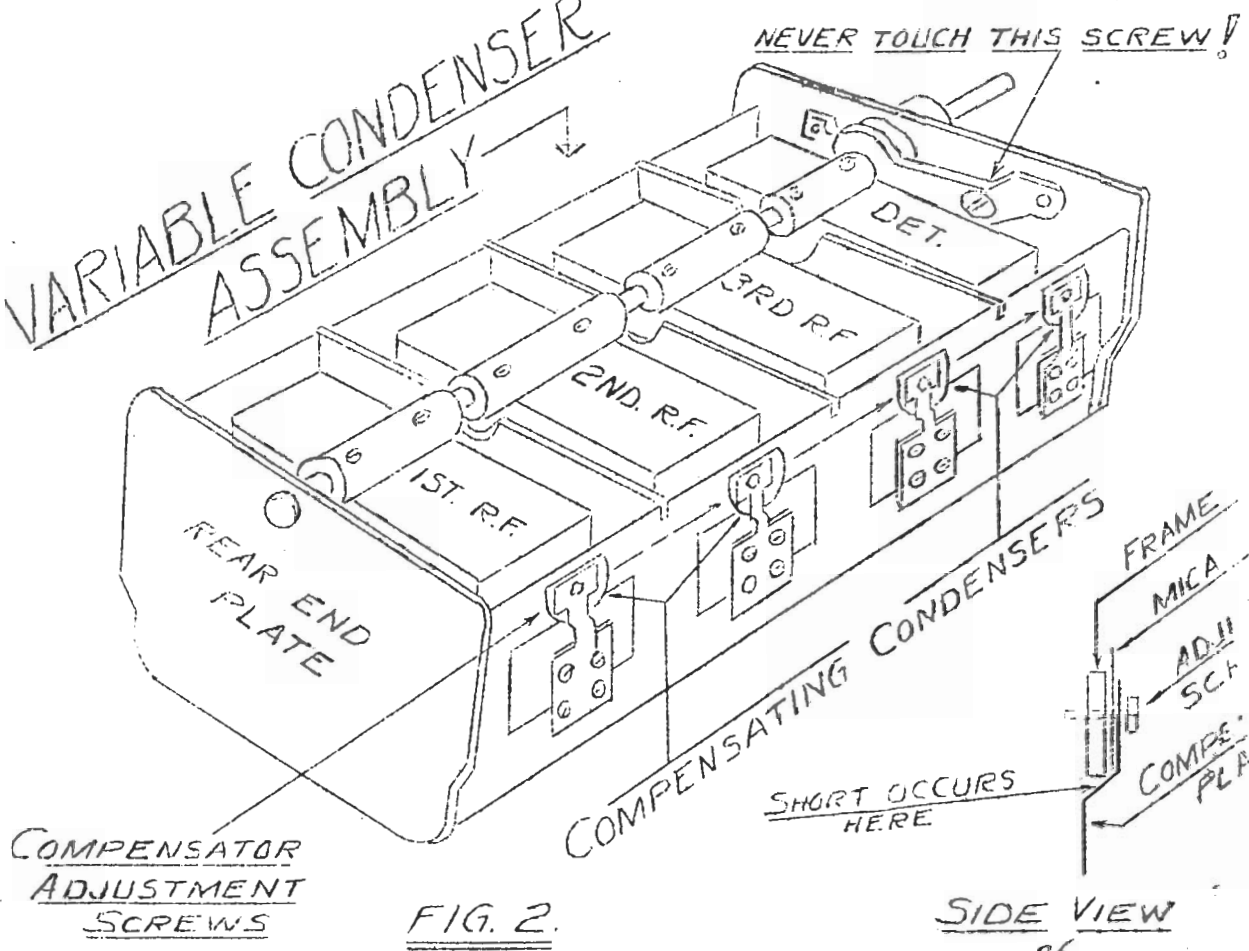

FIG. 2.

SIDE VIEW  
of  
COMPENSATOR PLATE  
FIG. 3.

TO ACCOMPANY BULLETIN #15.

RADIO SERVICE DEPARTMENT

Bldg #21

West Orange, N.J.

BULLETIN #16

FEBRUARY 21, 1929.

---

SPECIAL BULLETIN FOR EDISON RADIO SERVICE ENGINEERS

---

SUBJECT: "Intermittent Operation or Starting and Stopping".

1. A few letters have reached us complaining of intermittent operation. That is, the set stops playing, then starts of its own accord or when the position of the set is changed or the chassis jarred.

2. In some cases the radio frequency compensating condensers are set up tightly (maximum capacity) against the condenser frame. Sometimes this tight adjustment is necessary for accurate balance, particularly on the detector compensator.

3. Then, it may be possible that a "near short" or complete short will exist at the bend in the compensator plate, from the bending point to condenser frame. If a "near short" exists, that is if the compensator plate is practically touching the condenser frame, a slight jar or vibration, such as occurs when one walks across the floor will result in a complete short and the set stops operating. Then again, another such jar or vibration will remove the short and set will voluntarily begin operating.

4. If such a condition is found remove the compensator adjustment screw. Pull out the compensator plate and bend downward slightly, so that when replaced the bent portion of compensating plate cannot contact with the frame and this trouble will forever be eliminated.

5. In the latest production sets such trouble is not expected to appear as the shape of the compensating plates has been slightly altered to remove such possibility of shorting.

6. See the attached drawing for more details.

P. J. McGee, T.A.V.P.  
RADIO PHONO DIVISION  
THOS. A. EDISON, INC.

RADIO SERVICE DEPARTMENT

Bldg. #21

West Orange, N.J.

BULLETIN #17

FEBRUARY 22, 1929.

---

SPECIAL BULLETIN FOR EDISON RADIO SERVICE ENGINEERS

---

SUBJECT: "Low Volume".

1. When the antenna and ground installation has been thoroughly checked and found OKEY, and when by test and exchange you are assured that all tubes are in perfect condition and yet volume is not satisfactory it is recommended that the chassis be removed and an inspection of antenna and ground binding posts be made.

2. You will note that the antenna binding post is mounted on a bakelite insulating plate. In the earlier production sets, serial numbers below 2500, it was regular procedure to insert the binding post shaft in hole, attach the conoyd connecting lug, then cover the lug with an oxidized split washer, on top of which combination was screwed the hexagon holding nut.

3. A test of this circuit, as indicated on attached figure, will show that nine out of ten such hook-ups will not pass current, when a low resistance meter is used for a continuity check. When this is true "low volume" results.

4. To correct this condition remove the hexagon nut, split washer and connecting lug. Now place the lock washer on threaded shaft, directly against bakelite plate, then place the conoyd lug in position, locking securely with hexagon nut. A continuity test will now indicate a perfect electrical joint.

5. Follow the same procedure in connection with ground post, placing the lock washer direct against chassis frame, with the conoyd lug directly under the lock nut.

6. With the original method, when the conoyd connecting lug is not directly contacting with thread on binding post shaft incoming signals must feed through a very high resistance joint formed by the highly oxidized surface of the lock washer, resulting in loss of volume.

P. J. McGee, T. A. V. P.  
RADIO-PHONO DIVISION,  
THOS. A. EDISON, INC.



RADIO SERVICE DEPARTMENT

Bldg. 21

West Orange, N. J.

Bulletin #18

March 11, 1929

---

SUBJECT: Returned Radio Parts

---

There has been some delay in making return shipment of Radio Parts sent to the Factory for replacement - and in issuing credit for defective parts.

Return shipments to the Factory should be made on or before the 1st and 15th of each month.

Your cooperation in this will greatly facilitate return shipments of Radio Parts to you and will enable us to quickly issue credit on defective parts returned to the factory.

T. A. EDISON, INC.  
RADIO PHONO DIVISION  
ORANGE, N. J.

---

SPECIAL BULLETIN FOR EDISON RADIO SERVICE ENGINEERS

---

SUBJECT:- Radio frequency Modulation hum.

We have found this hum is eliminated by using the variable 227 hum adjuster (R-8) on the 226 radio frequency filament and substituting the fixed center tapped resistor (R-10) in its place across the 227 detector filament as per the following directions:

4 - Change Hum Adjustors.

- (a) Remove fixed center tap resistance from R.F. filament lugs.
- (b) Disconnect variable center tap resistance leads from detector filament lugs and connect these leads to R. F. filament lugs after twisting leads together and cutting to length.
- (c) Solder one terminal of fixed center tap resistor directly to one of the detector filament lugs (a convenient position for the resistor is at right angles to the set terminal strip). Connect the other filament lug to the other end of the resistor. Connect the center terminal of the resistor to the lug between the R.F. filament lugs on the set terminal strip.
- (d) Disconnect variable center tap resistance leads for first audio filament, twist together and replace.
- (e) Tune variable center taps by the following method. Set either adjustment considerably to one side of center and adjust the other for minimum hum. Then move the first adjuster slightly nearer to center and readjust second. Repeat this process until the best minimum has been reached. If necessary reverse plugs as described in paragraph two and repeat adjustments.

